



Hydrate Z140

A heavy-duty, stylish Drinking Fountain with Bubbler only. Constructed from marine grade Aluminium extrusion.



Part of a range



Wheelchair access

Quality & durability

- Heavy-duty marine grade Aluminium Extrusion
- Bubbler with vandal-resistant shroud
- Attractive vinyl graphic information sign
- Surface mounted

Important notes:

- The bubbler mechanism is inadvisable for temperatures consistently below 4°C, unless appropriate mitigation practices are implemented on-site.
- Fountain requires mains pressure to ensure optimal performance.
- Water pressure supply should range between 100-400kpa.

Ideal for

- Schools
- Council Parks
- Walkways
- Public Spaces

Finishes available

- Powder coated silver pearl (standard)
- Custom colour choice available (addition cost).

Specifications

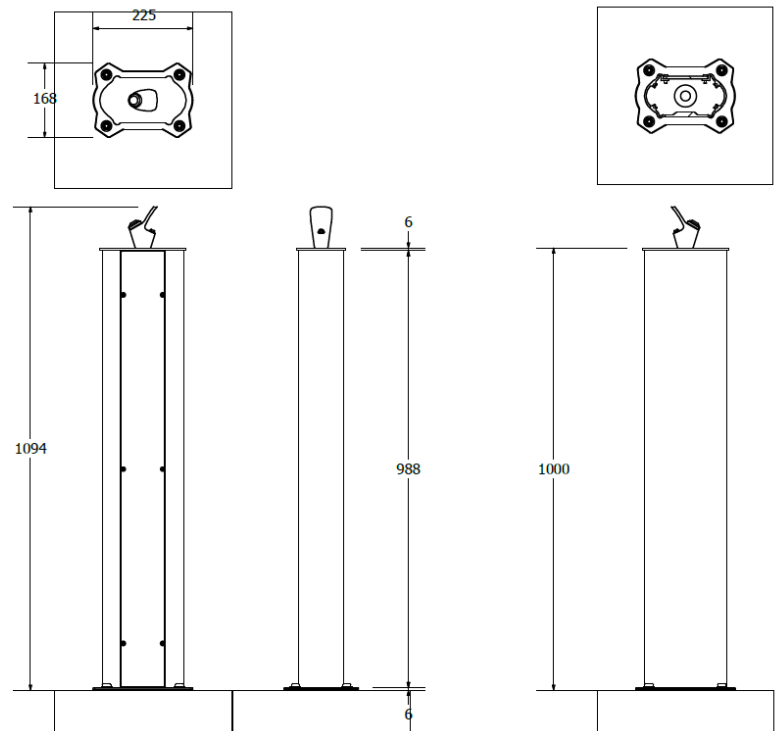

Other products in the *Hydrate* range

- Hydrate Drinking Fountain Model Z140
- Hydrate Drinking Fountain Model Z240
- Hydrate Drinking Fountain Model Z340
- Hydrate Drinking Fountain Model Z440
- Hydrate Drinking Fountain Model Z540

To view other products in the *Hydrate* range, visit our website

Contact us today

Freephone 0508 4 URBAN or visit urbaneffects.co.nz





Hydrate Z240

A heavy-duty, stylish Drinking Fountain with Bottle Filler only. Constructed from marine grade Aluminum extrusion.



Part of a range



Wheelchair access

Quality & durability

- Heavy-duty marine grade Aluminium Extrusion
- Bottle Filler with vandal-resistant shroud
- Attractive vinyl graphic information sign
- Surface mounted

Important notes:

- The bubbler mechanism is inadvisable for temperatures consistently below 4°C, unless appropriate mitigation practices are implemented on-site.
- Fountain requires mains pressure to ensure optimal performance.
- Water pressure supply should range between 100-400kpa.

Ideal for

- Schools
- Council Parks
- Walkways
- Public Spaces

Finishes available

- Powder coated silver pearl (standard)
- Custom Colour Choice Available (addition cost).

Specifications

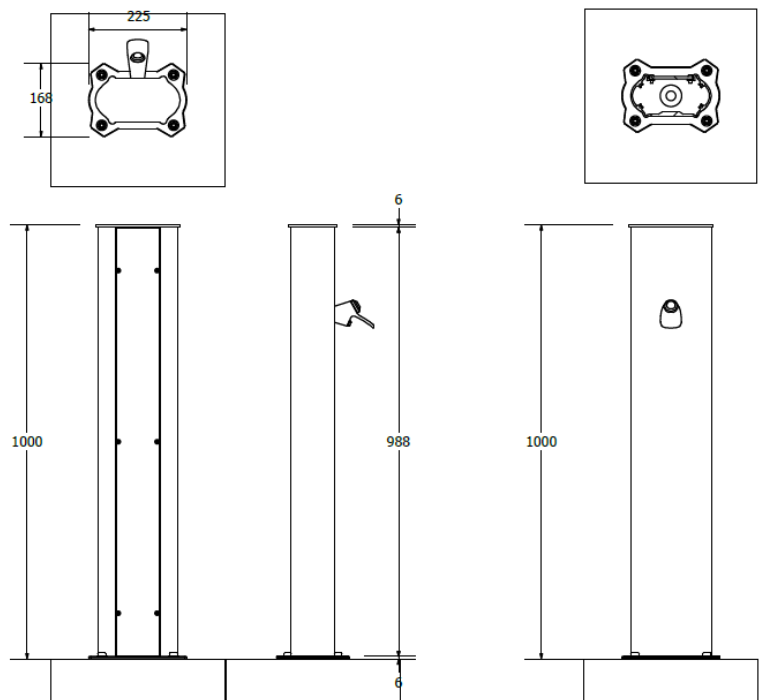

Other products in the *Hydrate* range

- Hydrate Drinking Fountain Model Z140
- Hydrate Drinking Fountain Model Z240
- Hydrate Drinking Fountain Model Z340
- Hydrate Drinking Fountain Model Z440
- Hydrate Drinking Fountain Model Z540

To view other products in the *Hydrate* range, visit our website

Contact us today

Freephone **0508 4 URBAN** or visit urbaneffects.co.nz





Hydrate Z340

A heavy-duty, stylish Drinking Fountain with Bubbler and Bottle Filler with vandal resistant tap shrouds. Constructed from marine grade Aluminum extrusion.



Part of a range



Wheelchair access

Quality & durability

- Heavy-duty marine grade Aluminium Extrusion
- Bubbler with vandal-resistant shroud
- Bottle Filler with vandal-resistant shroud
- Attractive vinyl graphic information sign
- Surface mounted

Important notes:

- The bubbler mechanism is inadvisable for temperatures consistently below 4°C, unless appropriate mitigation practices are implemented on-site.
- Fountain requires mains pressure to ensure optimal performance.
- Water pressure supply should range between 100-400kpa.

Ideal for

- Schools
- Council Parks
- Walkways
- Public Spaces

Finishes available

- Powder coated silver pearl (standard)
- Custom Colour Choice Available (addition cost).

Specifications

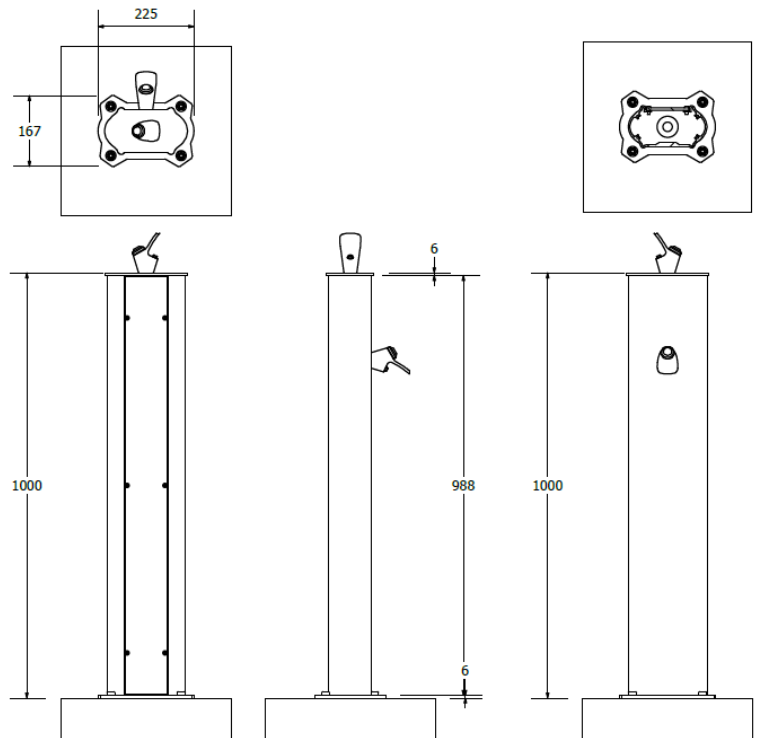

Other products in the *Hydrate* range

- Hydrate Drinking Fountain Model Z140
- Hydrate Drinking Fountain Model Z240
- Hydrate Drinking Fountain Model Z340
- Hydrate Drinking Fountain Model Z440
- Hydrate Drinking Fountain Model Z540

To view other products in the *Hydrate* range, visit our website

Contact us today

Freephone **0508 4 URBAN** or visit urbaneffects.co.nz





Hydrate Z440

A heavy-duty, stylish Drinking Fountain with Bubbler, Bottle Filler and external hose connection with vandal resistant tap shrouds. Constructed from marine grade Aluminum extrusion.



Part of a range



Wheelchair access

Quality & durability

- Heavy-duty marine grade Aluminium Extrusion Bubbler
- with vandal-resistant shroud
- Bottle Filler with vandal-resistant shroud
- External hose connection with vandal-resistant shroud
- Attractive vinyl graphic information sign
- Surface mounted

Important notes:

- The bubbler mechanism is inadvisable for temperatures consistently below 4°C, unless appropriate mitigation practices are implemented on-site.
- Fountain requires mains pressure to ensure optimal performance.
- Water pressure supply should range between 100-400kpa.

Ideal for

- Schools
- Council Parks
- Walkways
- Public Spaces

Finishes available

- Powder coated silver pearl (standard)
- Custom Colour Choice Available (addition cost).

Specifications

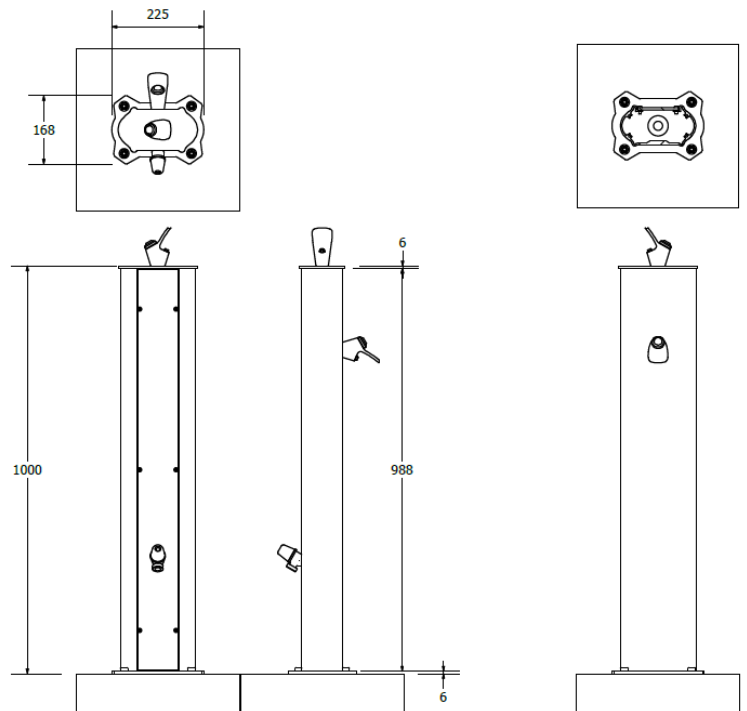

Other products in the *Zenith* range

- Hydrate Drinking Fountain Model Z140
- Hydrate Drinking Fountain Model Z240
- Hydrate Drinking Fountain Model Z340
- Hydrate Drinking Fountain Model Z440
- Hydrate Drinking Fountain Model Z540

To view other products in the *Hydrate* range, visit our website

Contact us today

Freephone **0508 4 URBAN** or visit urbaneffects.co.nz



Hydrate Z450

A heavy-duty, stylish Drinking Fountain with Bubbler, Bottle Filler, dog bowl and external hose connection with vandal resistant tap shrouds. Constructed from marine grade Aluminum extrusion.



Part of a range



Wheelchair access

Quality & durability

- Heavy-duty marine grade Aluminium Extrusion Bubbler
- with vandal-resistant shroud
- Bottle Filler with vandal-resistant shroud
- External hose connection with vandal-resistant shroud
- Attractive vinyl graphic information sign
- Surface mounted
- Dog Bowl

Important notes:

- The bubbler mechanism is inadvisable for temperatures consistently below 4°C, unless appropriate mitigation practices are implemented on-site.
- Fountain requires mains pressure to ensure optimal performance.
- Water pressure supply should range between 100-400kpa.

Ideal for

- Schools
- Council Parks
- Walkways
- Public Spaces

Finishes available

- Colour Powdercoated Aluminium

Specifications

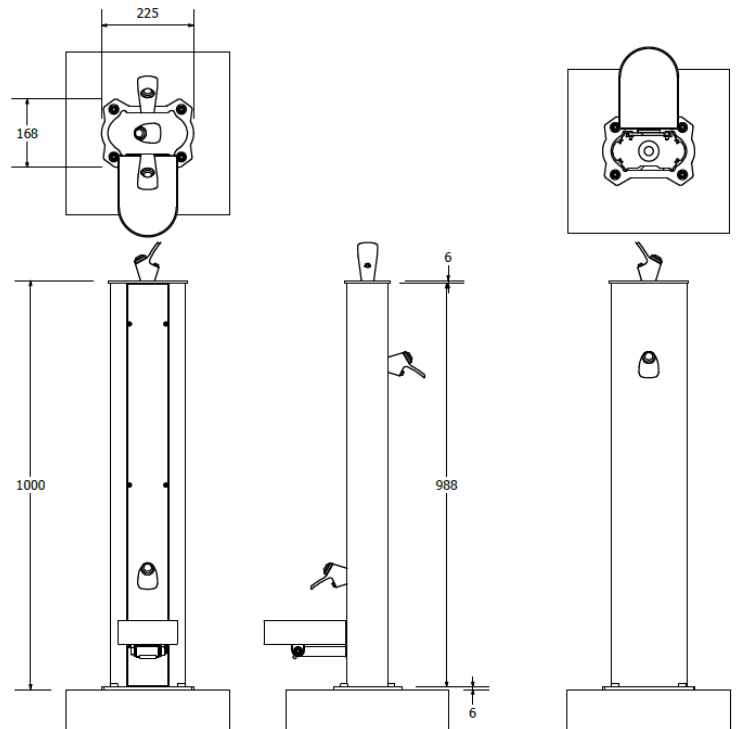

Other products in the *Zenith* range

- Hydrate Drinking Fountain Model Z140
- Hydrate Drinking Fountain Model Z240
- Hydrate Drinking Fountain Model Z340
- Hydrate Drinking Fountain Model Z440
- Hydrate Drinking Fountain Model Z540

To view other products in the *Hydrate* range, visit our website

Contact us today

Freephone **0508 4 URBAN** or visit urbaneffects.co.nz

